

Product Information

FIECOFLAT45-WP - Eco-Flat Chimes Angled

BS EN 1176 - Designed to British & European Standards



MATERIALS

- Panels** - Two Colour High Density Polyethylene (HDPE)
- Posts** - 100% recycled plastic with a heavy textured finish
- Chimes** - Multi-coloured anodised aluminium flat chimes

SUPPLY METHOD

- Panel** - Assembled
- Posts** - Includes post caps & fixings
- Beaters** - Assembled

FEATURES

-  **INCLUSIVE** - Chimes positioned at easily accessible height
-  **MUSICAL** - Set of 8 musically tuned chimes



DIMENSIONS

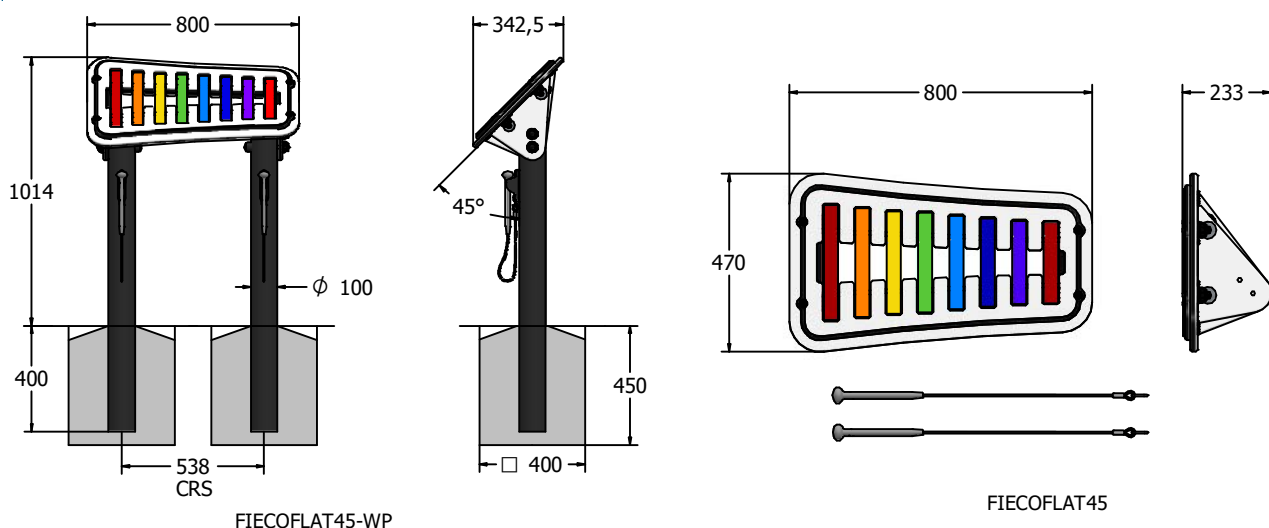

TECHNICAL

Age Range: 2+ Years
Largest Part: FIECOFLAT45-WP - 1414 x 800 x 342.5mm
Heaviest Part: FIECOFLAT45 - 12.5kg Approx.
Total Weight: 29kg Approx.
Surfacing: N/A

Age Range: 2+ Years
Largest Part: FIECOFLAT45 - 470 x 800 x 233mm
Total Weight: 12.5kg Approx.
Surfacing: N/A

IMPORTANT: you must specify the colour option you require at the time of order if it is different from the colour listed/shown above, requirements are subject to availability at the time of order