

Product Information

FIPTREHGRG - Henge Reactions

BS EN 1176 - Designed to British & European Standards

MATERIALS

Panel - Two Colour High Density Polyethylene (HDPE)

Post & Edge Beam - Extruded aluminium with powder coat finish

SUPPLY METHOD

Columns - Pre-assembled Units

Foundation Brackets - Supplied Separately

Linking Cables - Supplied Separately



FEATURES

 **ROTOGEN**- Human powered energy for electronics

 **REACTIONS** - Speed based reaction gameplay

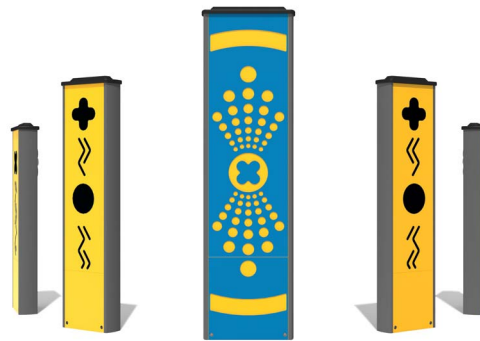

DIMENSIONS

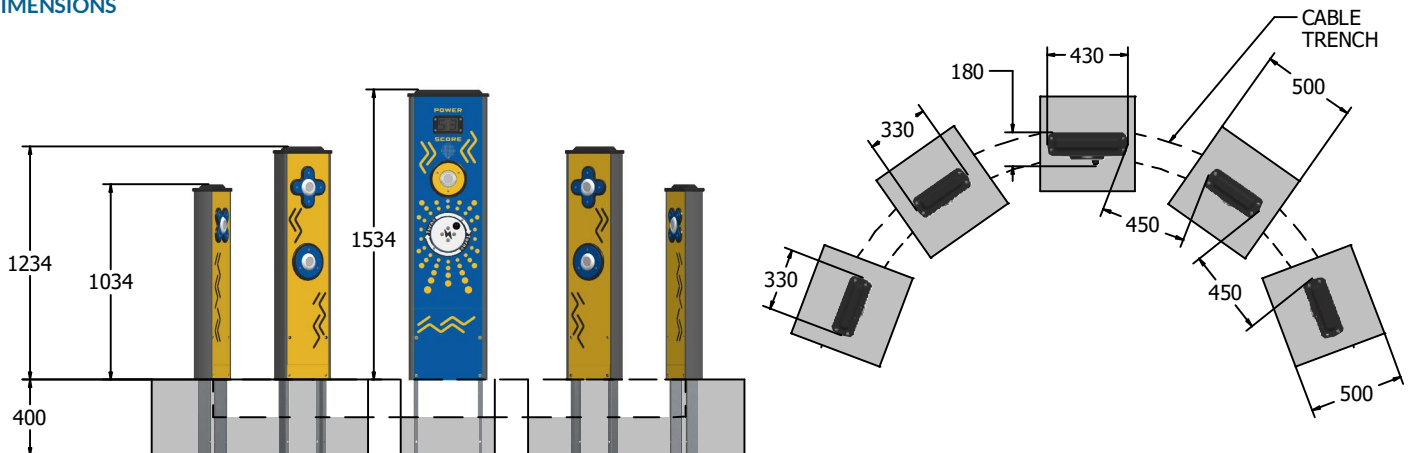

TECHNICAL

Age Range: 4+ Years
 Largest Part: Central Henge Column - 1534 x 430 x 180mm
 Heaviest Part: Central Henge Column - 28kg
 Total Weight: 105kg
 Surfacing: N/A

IMPORTANT: you must specify the colour option you require at the time of order if it is different from the colour listed/shown above, requirements are subject to availability at the time of order