

# Product Information

## FIMU50TUSCNS8 - 50mm Tube Chime - Screw Fixing - Silver - Set of 8 - Diatonic

BS EN 1176 - Designed to British & European Standards

### MATERIALS

**Tube Chimes** - Anodised aluminium with a brushed finish

### SUPPLY METHOD

**Tube Chimes** - Individual including rubber grommets

**Screw Fixings** - 2 sets per chime

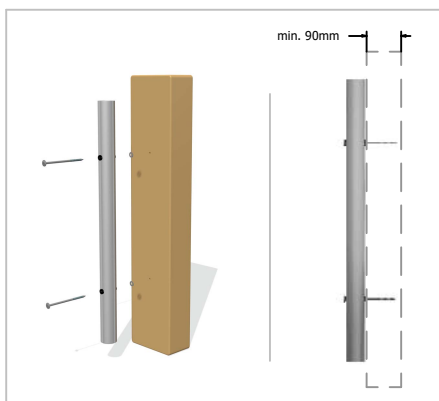

Easily attach to your own surface

### Choice of Beaters Available Separately:

**FSU0901**  
Large Beater & Cable



**FIBEATLGSCREW**  
Large Beater & Holder  
with Screw Fixing



**FIBEATLGBOLT**  
Large Beater & Holder  
with Bolt Fixing



### DIMENSIONS

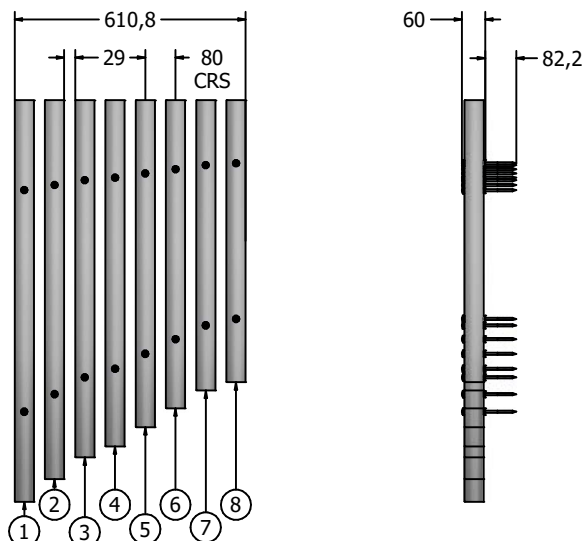

Item	Product Code	Length	Note	Qty
1	FIMU50TUSCNSC4	1062.5	C4	1
2	FIMU50TUSCNSD4	1002.5	D4	1
3	FIMU50TUSCNSSE4	945	E4	1
4	FIMU50TUSCNSF4	916	F4	1
5	FIMU50TUSCNSG4	865	G4	1
6	FIMU50TUSCNSA4	815	A4	1
7	FIMU50TUSCNSB4	768	B4	1
8	FIMU50TUSCNSC5	746	C5	1

Chimes available separately to mix and match

### TECHNICAL

**Age Range:** 2+ Years  
**Largest Part:** C4 Chime - 1062.5 x  $\phi$ 50.8mm  
**Heaviest Part:** C4 Chime - 1.5kg Approx.  
**Total Weight:** 10.5kg Approx.  
**Surfacing:** N/A

IMPORTANT: you must specify the colour option you require at the time of order if it is different from the colour listed/shown above, requirements are subject to availability at the time of order