

Product Information

FITSSNAKEIN - Tile Slide Snake Insert

BS EN 1176 - Designed to British & European Standards

MATERIALS

Panel - Two Colour  High Density Polyethylene (HDPE)

SUPPLY METHOD

Insert - Fully assembled

FEATURES

 **SLIDERS** - Tile slide snake puzzle

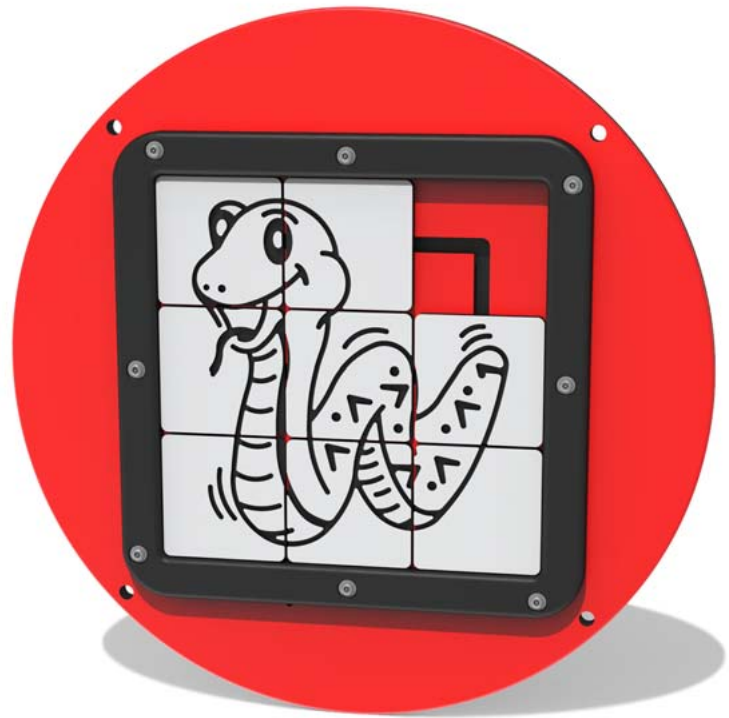

Insert can easily attach to your own panel

DIMENSIONS

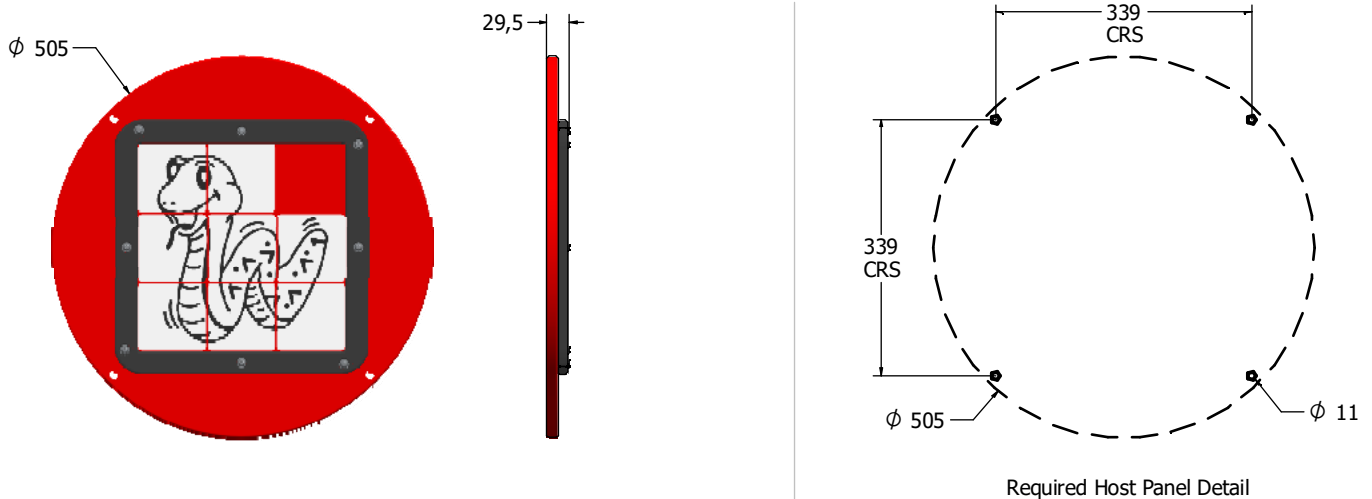

TECHNICAL

Age Range: 2+ Years
 Largest Part: ϕ 505 x 29.5mm
 Total Weight: 4kg Approx.
 Surfacing: N/A

IMPORTANT: you must specify the colour option you require at the time of order if it is different from the colour listed/shown above, requirements are subject to availability at the time of order