

Product Information

FIEXPENG - Steam Express - Engine

BS EN 1176 - Designed to British & European Standards

MATERIALS

Panels - Two Colour High Density Polyethylene (HDPE)

Recycled Profile - Recycled plastic with textured finish

LumbeRock Benches - Recycled HDPE milk bottles with a wood grain finish

SUPPLY METHOD

Steam Express - Fully assembled

FEATURES

 **SOCIAL** - Encourages Imaginative Play

 **TUNNEL** - Crawl Thru Tunnel

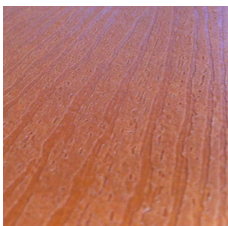

LumbeRock Benches

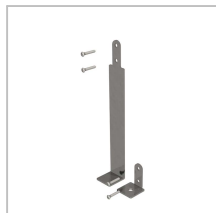

Surface & below ground fixings sold separately

DIMENSIONS

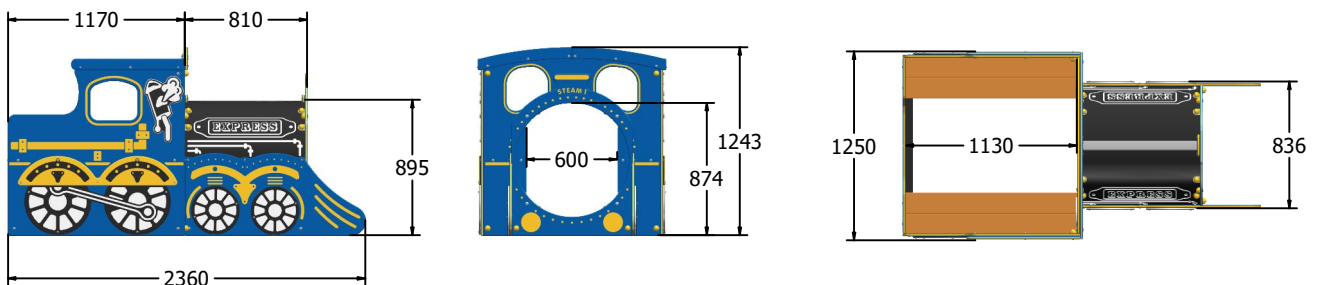

TECHNICAL

Age Range: 2+ Years
Largest Part: FIEXPENG - 2360 x 1243 x 1250mm
Total Weight: FIEXPENG - 153kg
Surfacing: 1.5m from the extents of the equipment with a critical fall height in excess of 895mm

IMPORTANT: you must specify the colour option you require at the time of order if it is different from the colour listed/shown above, requirements are subject to availability at the time of order

Product Information

FIEXPCARR - Steam Express Carriage

BS EN 1176 - Designed to British & European Standards

MATERIALS

Panels - Two Colour High Density Polyethylene (HDPE)

Recycled Profile - Recycled plastic with textured finish

LumbeRock Benches - Recycled HDPE milk bottles with a wood grain finish

SUPPLY METHOD

Carriage - Fully assembled

FEATURES

 **SOCIAL** - Carriage seating

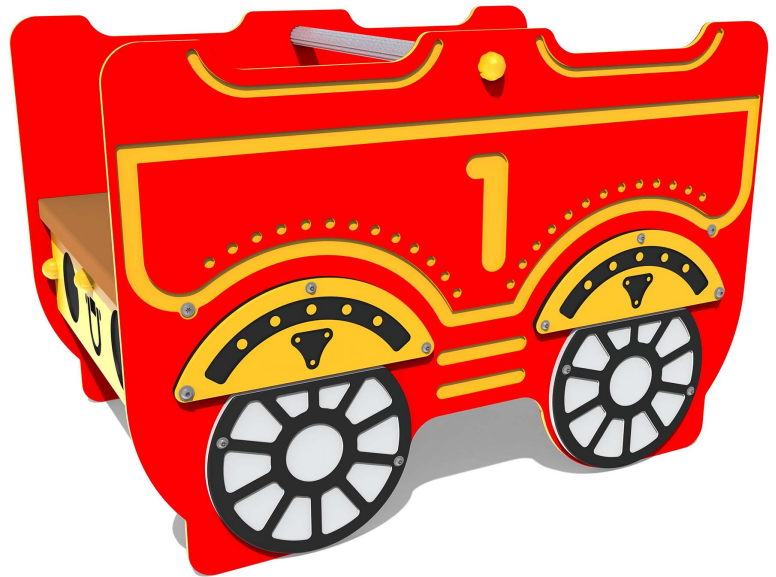

FIEXPCARR1 - Carriage 1



FIEXPCARR2 - Carriage 2



FIEXPCARR3 - Carriage 3

DIMENSIONS

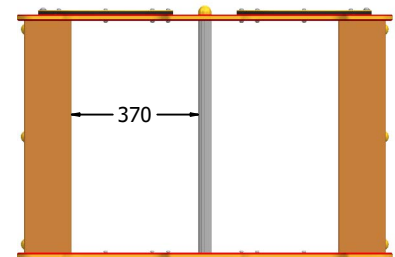
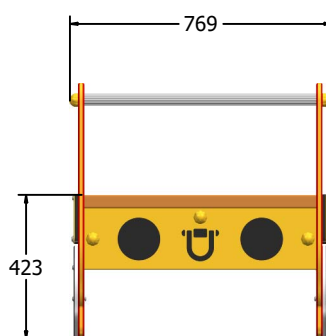
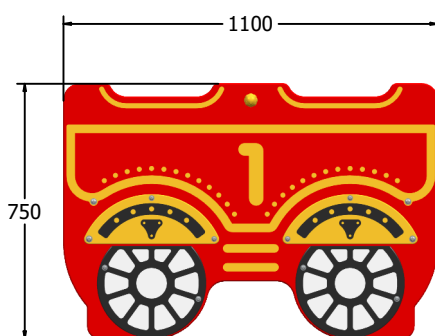

TECHNICAL

Age Range: 2+ Years
Largest Part: FIEXPCARR1 - 750 x 1000 x 769mm
Total Weight: FIEXPCARR1 - 48kg
Surfacing: N/A

IMPORTANT: you must specify the colour option you require at the time of order if it is different from the colour listed/shown above, requirements are subject to availability at the time of order