

# Product Information

## FS2021 - Sit-In Craig Crocodile Spring Rocker

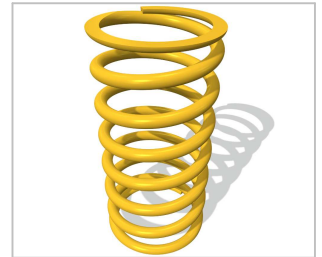

High Quality Steel Spring

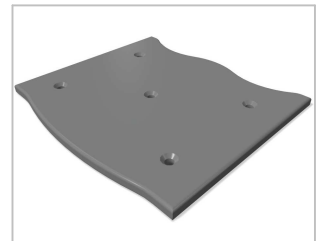

Smooth Polydek Seat

Designed to British & European  
Standard BS EN 1176

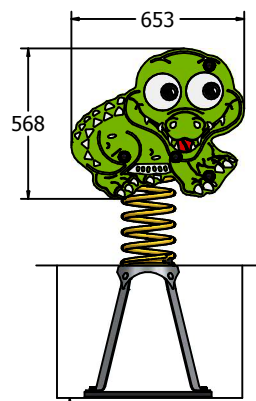
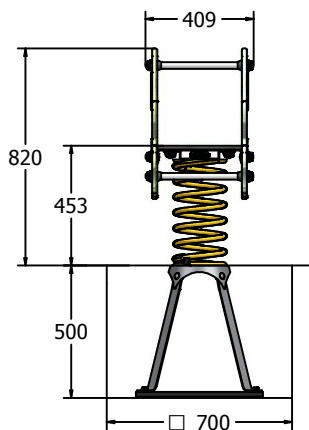

Foundation back-filled

Supply Method

Crocodile Assembly  
Assembled with Fixing Pack  
& Instructions

400mm Spring Assembly  
Fully Assembled

Ground Anchor  
Loose Components with Fixing Pack  
& Instructions

Age Range: 2+ Years  
Largest Part: Crocodile Assembly - 653x568x409mm  
Heaviest Part: Spring Assembly 20 Kg approx.  
Total Weight: 37.5 Kg approx.  
FFH (Free Fall Height): 453mm  
Surfacing : 1m from extremes of equipment with a Critical Fall Height in excess of 600mm

Inspection Schedule	Inspection Frequency
Visual	Every Month
Functionality	Every Month
Comprehensive	Every 6 Months

Material: **Design Panel** - High Density Polyethylene (HDPE) with orange peel texture finish  
**Spring & Brackets** - Powder coated steel  
**Ground Anchor** - Galvanised steel

Colour Choices: **Design Panel** - Broad selection available, visit the website below for further details